

1. DUMLUPINAR = 3476415829

⇒ PUANLI = ?

- A) 124865      B) 142856      C) 142865  
D) 341856      E) 324865

2. I                      II  
 35624 } ⇒ { 46978  
 72653 }    { 69287  
 65372 }    { 96482  
 42356 }    { 78469  
 53427 }    { 28964

⇒ 549723 = ?

I. Gruptaki sayıların rakamları birer rakam ile gösterilerek  
 II. Gruptaki sayılar elde edilmiştir. Buna göre, 549723  
 hangi sayı ile gösterilmiştir?

*The numbers in group II. stand for the number in group I  
 when each number has been coded with a specific  
 numeral. Which number corresponds to 549723?*

*Каждая цифра соответствует цифре. Цифры в  
 первой группе соответствуют цифрам второй  
 группы. Выберите какие из цифр подходят 549723  
 к этому набору цифр.*

*تم الحصول على ارقام المجموعة الثانية بحسب ارقام  
 المجموعة الأولى. بحسب ذلك، ما العدد الذي يمثل  
 327945 ؟*

- A) 625789      B) 624789      C) 623783  
D) 267843      E) 264879

3. ●ABCDEF → FEDCBA

KLMNPR▲ → RLPNMK

●TSVXYZ▲ → TYSVXZ

⇒ ●KCRXMT▲ = ?

- A) KMXCRT      B) KMXRCT      C) KMCXRT  
D) KMRXCT      E) KMCRXT

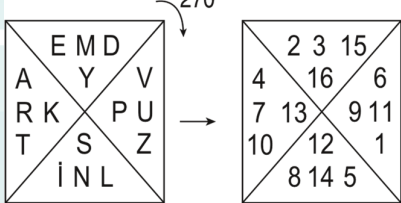
4. 
 The diagram shows a 3x3 grid of letters on the left, which is rotated 270 degrees clockwise to a 3x3 grid of numbers on the right. The letters grid is:
 

E	M	D
A	Y	V
R	K	P
T	S	Z
I	N	L

 The numbers grid is:
 

2	3	15
4	16	6
7	13	9
10	12	1
8	14	5

KARPUZ = K+A+R+P+U+Z = 68

⇒ SERENAD = ?

Yukarıda verilenler belirli bir kurala göre oluşturulmuştur.  
 Buna göre SERENAD = ?

*The above is based on a certain rule. According to this  
 SERENAD=?*

*В соответствии с определенными правилами,  
 приведенными выше, какое будет иметь значение  
 SERENAD = ?*

*تم انشاء المعطيات أعلاه بحسب قاعدة واحدة. بحسب ذلك، ما  
 قيمة DANERES ؟*

- A) 69                      B) 68                      C) 67  
D) 66                      E) 65

5.  $\left. \begin{matrix} x \otimes y = x + 3y \\ x \odot y = x \cdot y \end{matrix} \right\} \Rightarrow (5 \otimes 1) \odot (1 \otimes 1) = ?$

- A) 48                      B) 32                      C) 24  
 D) 21                      E) 15

6.  $\left[ \begin{matrix} 3 & 1 & x & 4 \\ + & 6 & y & 9 & 5 \\ 1 & 0 & 0 & 1 & 9 \end{matrix} \right], \left[ \begin{matrix} 4 & 9 & 1 & x \\ - & 3 & y & 0 & 1 \\ 1 & 1 & 1 & 1 & 1 \end{matrix} \right]$   
 $\Rightarrow x, y = ?$

- |      | x | y |
|------|---|---|
| A) 8 | 8 | 2 |
| B) 6 | 6 | 2 |
| C) 2 | 2 | 8 |
| D) 8 | 8 | 0 |
| E) 2 | 2 | 6 |

7.  $5 \boxtimes 3 = 20$   
 $4 \boxtimes 2 = 12$   
 $6 \boxtimes 5 = 36$   
 $7 \boxtimes 3 = ?$

- A) 10                      B) 16                      C) 21  
 D) 28                      E) 35

8.  $2^{x*y} = 4x + 5y \Rightarrow$   
 $3 * 4 = ?$

- A) 1                      B) 5                      C) 9  
 D) 3                      E) 4

9.

$$\begin{aligned} \text{☐} \text{☐} - \text{✂} + \begin{pmatrix} \text{☺} \\ \text{☺} \end{pmatrix} &= 33 \\ \begin{pmatrix} \text{☺} \\ \text{☺} \end{pmatrix} + \text{☐} \text{☐} + \text{✂} &= 24 \\ \text{✂} \text{✂} + \begin{pmatrix} \text{☺} \\ \text{☺} \end{pmatrix} + \text{☐} \text{☐} &= 28 \end{aligned}$$

$\Rightarrow \text{☐} + \text{✂} + \begin{pmatrix} \text{☺} \\ \text{☺} \end{pmatrix} = ?$

- A) 17                      B) 16                      C) 15  
D) 14                      E) 13

10.

+	a	b	c
a	12		
b			5
c			

$\Rightarrow (a - b - c)(a + b + c) = ?$

- A) 11                      B) 110                      C) 60  
D) 36                      E) 119

11.

Sonuç  
Result  
Результат  
نتيجة

8	6	1	27
7	3	2	45
9	6	3	39
4	2	5	?

- A) 40                      B) 27                      C) 37  
D) 20                      E) 18

12.

+	a	b	c
a			
b	10		
c			

x	a	b	c
a			36
b			
c		54	

$\Rightarrow c = ?$

- A) 5                      B) 6                      C) 7  
D) 8                      E) 9

13.

+	a	b	c
a			10
b	2c-3		
c		3a-1	

$a, b, c > 0$

$\Rightarrow a \cdot c + b = ?$

- A) 29                      B) 27                      C) 25  
 D) 23                      E) 21

14.

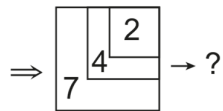
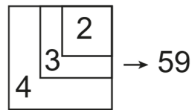
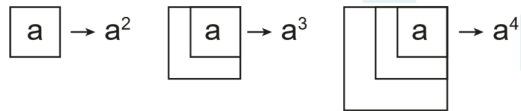

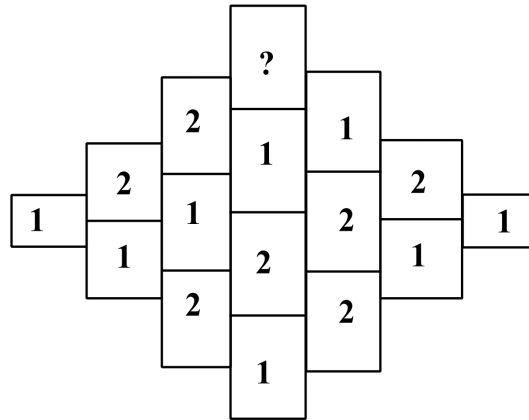

- A) 126                      B) 128                      C) 127  
 D) 129                      E) 125

15.





- A) 1                      B) 2                      C) 3  
 D) 4                      E) 5

16.

 +  =  $3 \cdot 2 + 4 \cdot 1 = 10$

 +  =  $6 \cdot 5 + 5 \cdot 4 = 50$

 +  = ?

- A) 42                      B) 39                      C) 47  
 D) 53                      E) 54

17.

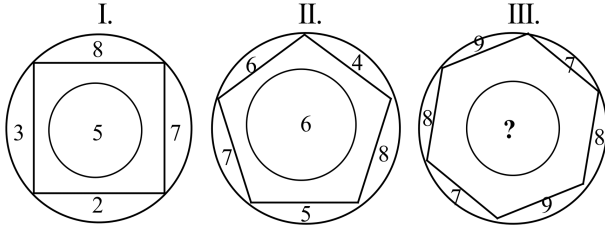

Yukarıdaki sayı diziliminde (?) yerine hangi sayı gelmelidir?

What number should be used in place of the number sequence (?) Above?

Какой номер следует использовать вместо последовательности чисел (?) Выше?

ما الرقم الذي يجب استخدامه بدلاً من تسلسل الرقم (?) أعلاه؟

A) 8

B) 6

C) 7

D) 5

E) 9

18. Aşağıdaki denge şekillerinden dengenin sağlanması için “?” yerine hangisi gelmelidir.

Which one should come instead of “?” to provide the balance from the balance shapes?

Следующее положение равновесия баланса для «?» вместо «какой».

ماذا ينبغي أن يأتي مكان (?) للحصول على توازن.

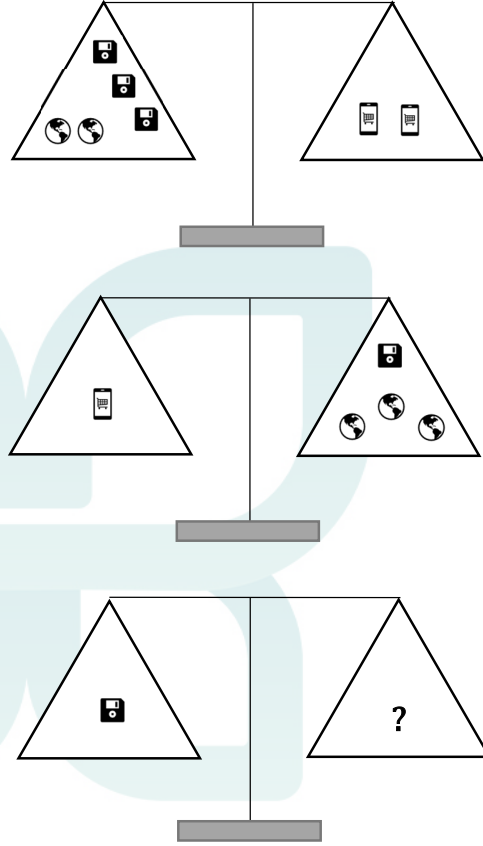

A)

B)

C)

D)

E)

19.

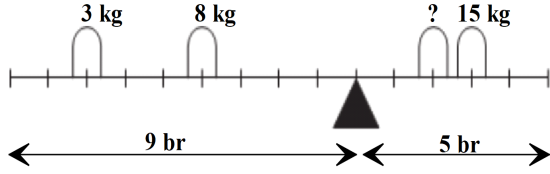

Şekildeki terazinin dengede kalması için soru işareti (?) yerine hangi ağırlık konulmalıdır.

Which weight should be put in place of the question mark (?) So that the scale in the figure remains in balance.

Какой вес следует поставить вместо знака вопроса (?), Чтобы баланс на рисунке оставался на балансе

اللغة العربية: ما الوزن الذي يجب وضعه بدلاً من علامة الاستفهام (?) من أجل الحفاظ على التوازن في الميزان؟

A) 3

B) 4

C) 5

D) 6

E) 7

20.

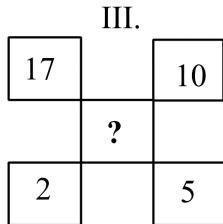
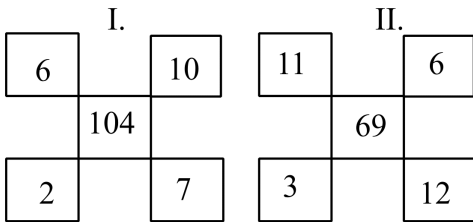

A) 170

B) 130

C) 176

D) 140

E) 172

21.



A)

C)

E)

B)

D)

22.

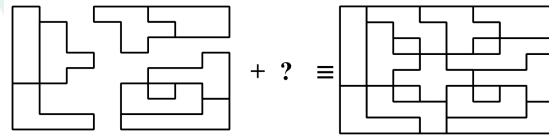

A)

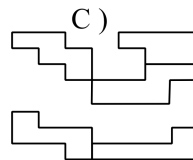
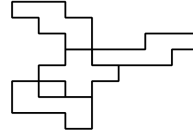

E)

B)

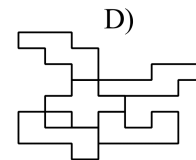
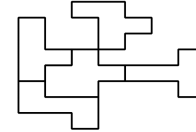

23.

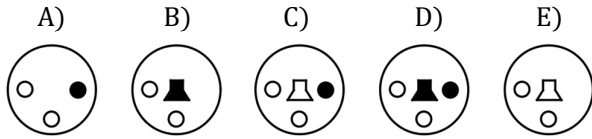
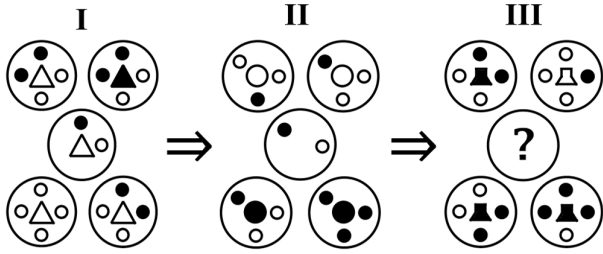

24.

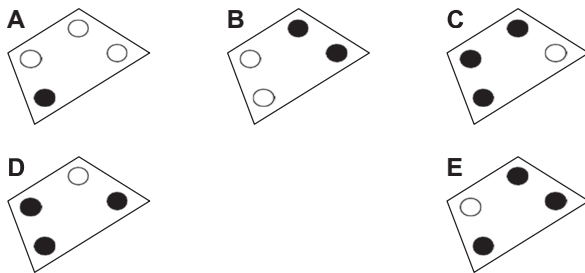
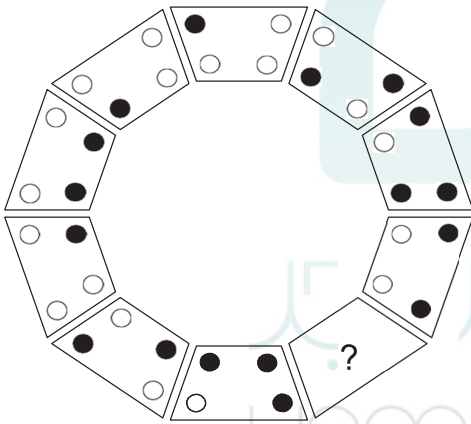

25.

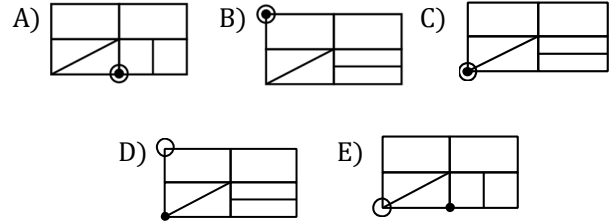
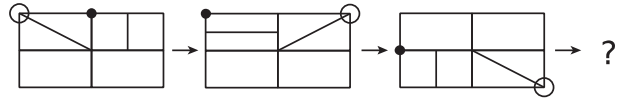

26.

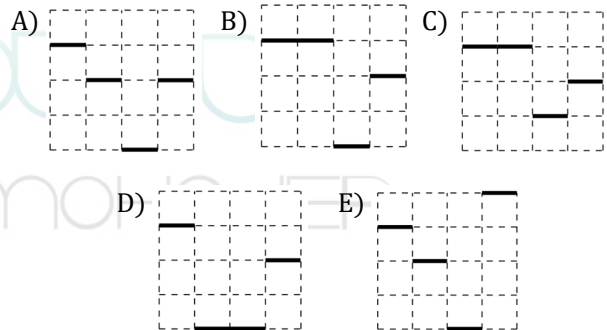
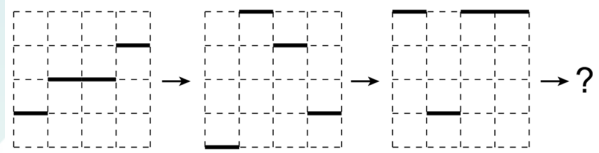

27.

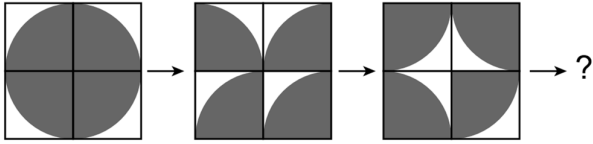

- A) B) C) D) E)

28.

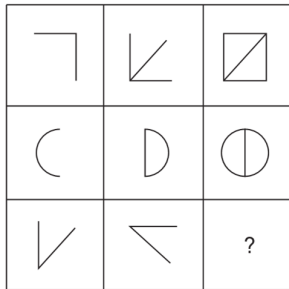

- A) B) C) D) E)

29.

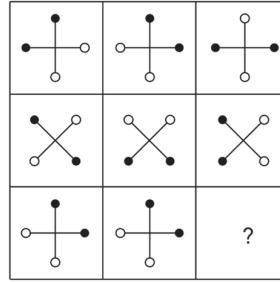

- A) B) C) D) E)

30.

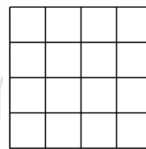
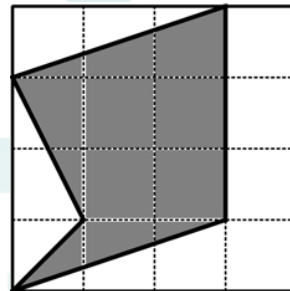

$= 16 br^2 \Rightarrow$

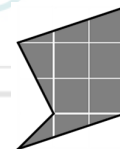

$= ? br^2$

- A)  $\frac{15}{2}$  B) 4 C)  $\frac{17}{2}$   
D) 9 E)  $\frac{19}{2}$



31. Aşağıdaki şekilde kaç üçgen bulunmaktadır?  
How many triangles are there in the shape above?  
Сколько треугольников следующим образом?

في الشكل الأعلى المذكور، كم مثلث يوجد.

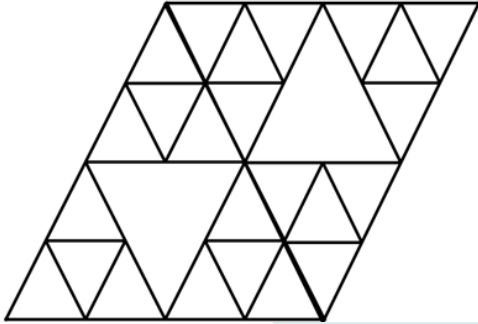

- A) 33      B) 34      C) 35  
D) 36      E) 37

32.

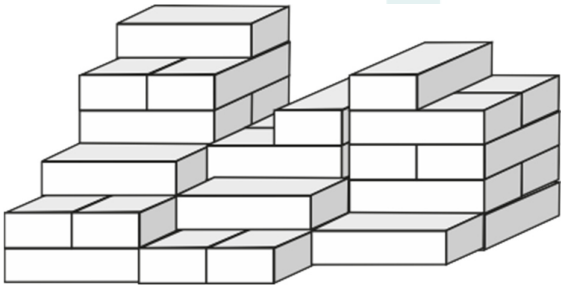

Tuğlaların hepsi aynı boyuttur. Bu yığında kaç tane tuğla vardır?

Bricks are all the same size. How many bricks are there in this stack?

кирпичи все одинакового размера. Сколько кирпичей в этом стеке?

العربية: الطوب واحد. كم عدد الطوب في هذا الكومة؟

- A) 32      B) 34      C) 36  
D) 38      E) 40

33.

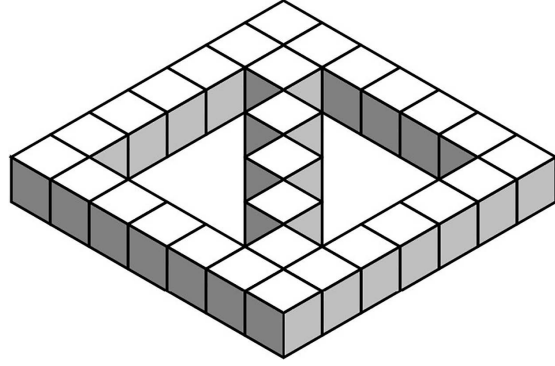

Yukarıdaki şeklin tamamlanması için boş alana kaç küp yerleştirilmelidir?

How many cubes should be placed in the empty space to complete the figure above?

Сколько кубиков нужно поместить в пустое пространство, чтобы завершить рисунок выше?

بالعربية: كم عدد المكعبات التي يجب عليك ملؤها لملء الرقم أعلاه؟

- A) 40      B) 50      C) 30  
D) 10      E) 20

34. 5 8 16 19 38 41 ?

Yukarıda verilen sayı dizisi belirli bir kurala göre oluşturulmuştur. Buna göre '?' yerine gelmesi gereken sayıyı bulunuz.

The number sequence above is based on a specific rule. What does the ? stand for.

Ряды чисел в соответствии с данным правилом, риведенным выше. Выберите какое из цифр подходят под знак .?.

تم انشاء سلسلة الاعداد اعلاه بحسب قاعدة واحدة. بحسب ذلك، اوجد العدد الذي يجب وضعه بدلا من اشارة الاستفهام

- A) 86      B) 49      C) 64  
D) 82      E) 45

Örnek/Sample/Образец/مثال

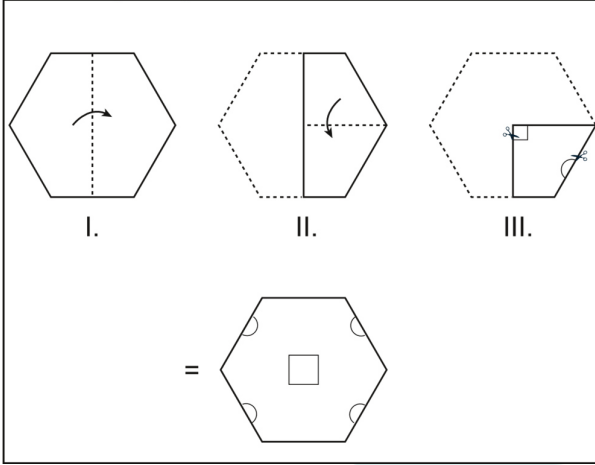

35.

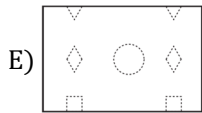
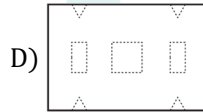
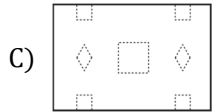
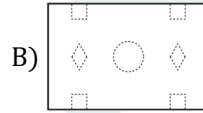
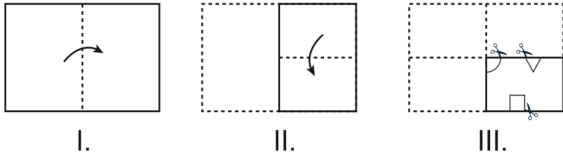

36.

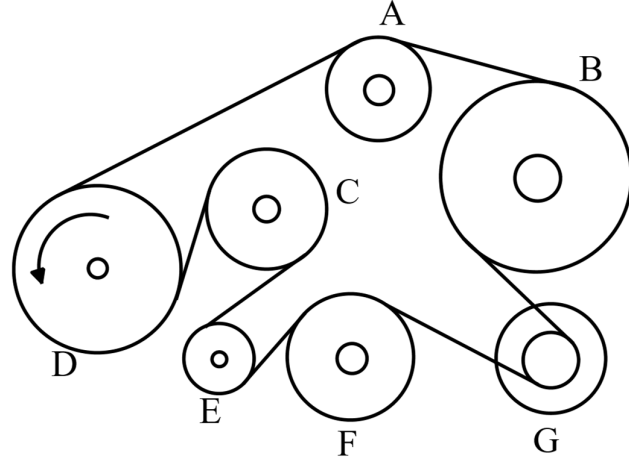

Dönme tekerleği (D) gösterilen yönde döndüğünde bağlı kayış diğer tekerlekleri çevirir, tekerleklerden hangisi en fazla döner.

Tied strap when the turning wheel (D) rotates in the direction shown turns other wheels, which wheel turns the most.

прикреплен ремень, когда вращающееся колесо (D) поворачивается в указанном направлении поворачивает другие колеса, какое колесо вращается наиболее.

في الاتجاه الموضح ، يدور العجلة (D) العربية : عندما تدور عجلة الدوران الحزام المرتبط العجلات الأخرى ، أيهما تدور العجلات بشكل أكبر.

A) C

B) E

C) A

D) F

E) G

37.

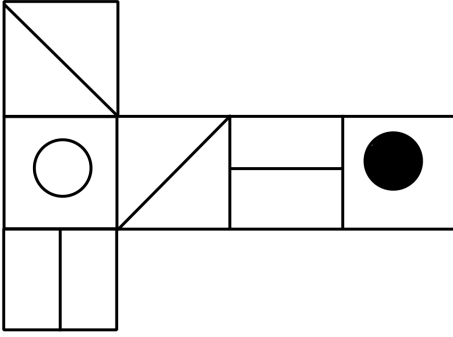

Yukarıdaki şekil bir küp oluşturmak üzere katlandığında, aşağıdakilerden sadece hangi ikisi üretilebilir.

Only two of the following can be produced when folded to form a cube of the above figure.

только два из следующих могут быть получены в сложенном виде, чтобы сформировать куб на рисунке выше.

اللغة العربية: يمكن إنتاج اثنين فقط مما يلي عند طيها لإنشاء مكعب من الشكل أعلاه

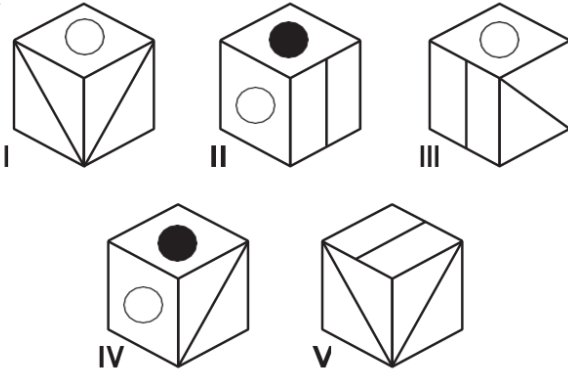

A) I, III

B) II, V

C) III, IV

D) I, IV

E) IV, V

38. Aşağıdaki şekillerden hangisi farklıdır?

Which of the following Figures is different?

Какая из следующих фигур отличается?

بالعربية: أي من الأشكال التالية مختلف؟

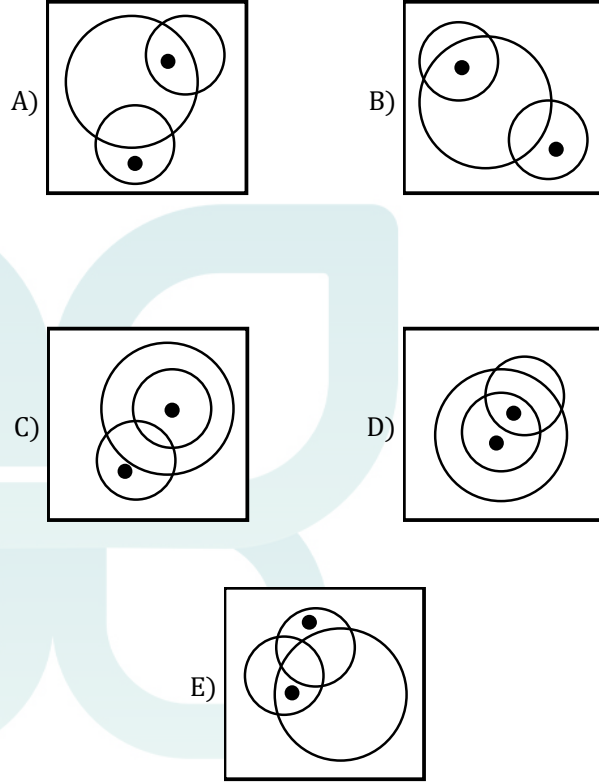

39.

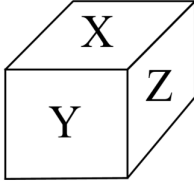

Şekildeki kapalı küpün karşılıklı yüzeyine aynı harfler yazılmıştır, küpün açılımı hangisidir?

The same letters are written on the opposite surface of the closed cube. Which is the opening of the cube?

Эти же буквы написаны на противоположной поверхности замкнутого куба. Если ваш куб откроется, какой вариант он будет?

نفس الحروف مكتوبة على السطح المقابل للمكعب المغلق. ما هو افتتاح المكعب؟

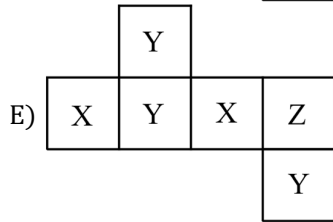
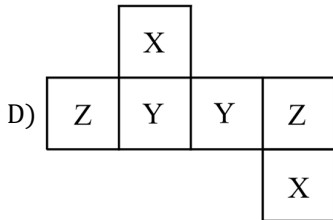
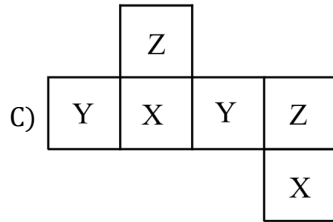
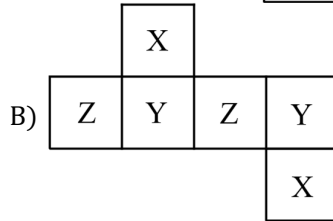
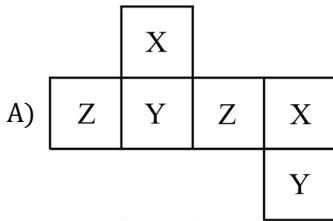

40.

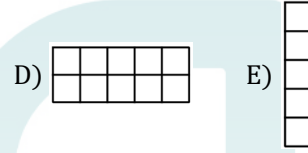
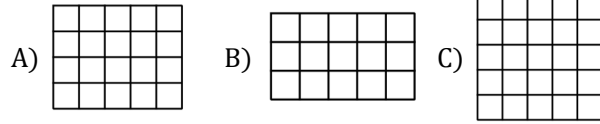
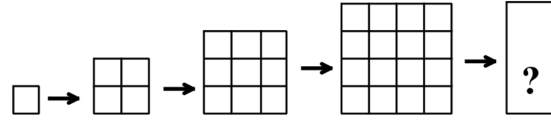

41. Aşağıdaki şekillerden hangisi farklıdır?

Which of the following Figures is different?

Какая из следующих фигур отличается?

بالعربية: أي من الأشكال التالية مختلف؟

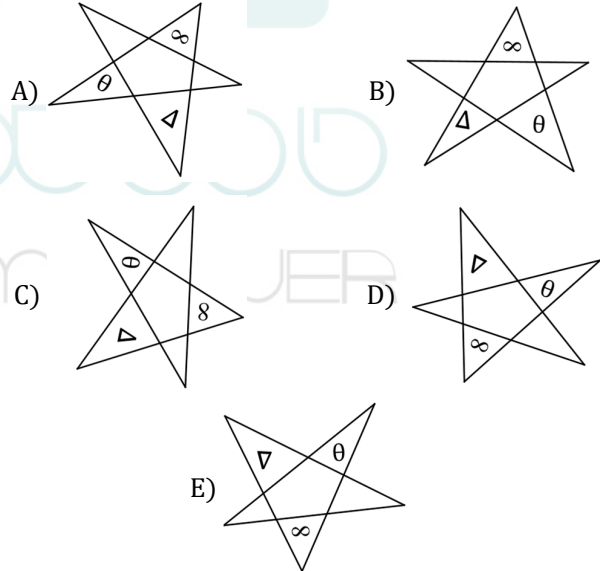

42.  $12K = 9L = 4M = 18N$

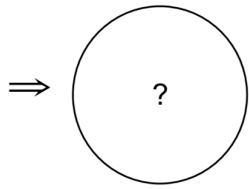

- A) B) C) D) E)

43.

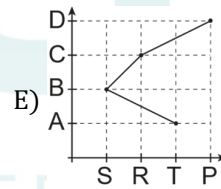
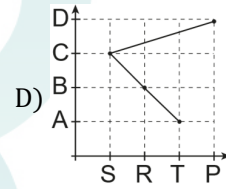
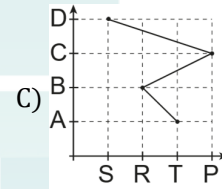
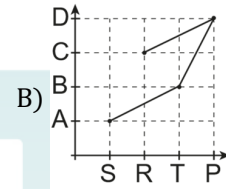
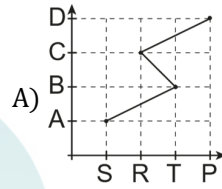
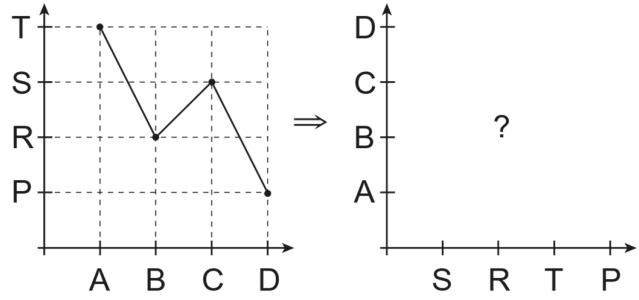

44. 
$$\begin{array}{r|l} 5KL & L5 \\ \hline & 7 \\ \hline \underline{\quad} & \\ \hline 3 & \end{array} \Rightarrow K = ?$$

A) 5

B) 6

C) 7

D) 8

E) 9

45. 
$$\begin{array}{r|l} abc0abcab & abc \\ \hline & ? \\ \hline \end{array}$$

A) 100100

B) 1000100

C) 1000010

D) 100010

E) 101000



جامعه علمی کاربردی  
همی موهجر

$$46. \frac{0,03}{0,003} + \frac{0,5}{0,05} + \frac{0,6}{0,03} = ?$$

- A) 40                      B) 50                      C) 60  
D) 30                      E) 20

$$48. \frac{\frac{3}{2} - \frac{1}{0,2 - 0,4} : 0,5}{0,5} = ?$$

- A)  $\frac{13}{2}$                       B) 9                      C)  $\frac{41}{3}$   
D) 21                      E) 33

$$47. \frac{1}{2} - \frac{2}{3} + \frac{3}{2} - \frac{4}{3} + \dots + \frac{11}{2} - \frac{12}{3} = ?$$

- A) -4                      B) 4                      C) 5  
D) -5                      E) -6

$$49. \frac{\frac{4}{\sqrt{3}-1} + \frac{2}{\sqrt{2}+1}}{\frac{1}{\sqrt{5}-2\sqrt{6}}} = ?$$

- A)  $\sqrt{6}$                       B)  $\sqrt{3}$                       C) 1  
D)  $\sqrt{2}$                       E) 2

50.  $a = \sqrt{5} + \sqrt{3}$

$$a^2 - 2\sqrt{3}a + 3 = ?$$

- A) 3                      B) 4                      C) 5  
                                 D) 6                      E) 7

51.  $\frac{x+9}{x-2} - \frac{2x}{x+1} = 5 - \frac{11}{2-x}$

$$\Rightarrow x = ?$$

- A)  $-\frac{2}{3}$                       B)  $-\frac{1}{2}$                       C) 1                      D) 2  
                                 D)  $\frac{3}{2}$                       E) 4                      E) 3                      E) 4

52. 
$$\left. \begin{array}{l} 2x + 5y - 7z = 8 \\ x + 2y - 2z = 6 \end{array} \right\} = x + y + z = ?$$

- A) 0                      B) 5                      C) 10  
                                 D) 15                      E) 25

53.  $\frac{a}{b} = \frac{2}{3}$

$$\frac{a+2b}{b-a} = ?$$

- A) 4                      B) 5                      C) 6  
                                 D) 7                      E) 8



54.  $x, y, z, t \in \mathbb{R}$ 

$$\left. \begin{array}{l} \frac{x}{y} = \frac{z}{t} = k \\ \frac{2x - 3z}{2y - mt} = k \end{array} \right\} \Rightarrow m = ?$$

- A) 6                      B) 4                      C) 5  
D) 3                      E) 7

55.  $2^{2018} - 2^{2017} - 2^{2016} - \dots - 2^1 = ?$ 

- A) 2                      B)  $2^{1000}$                       C)  $2^{1004}$   
D)  $2^{2017}$                       E)  $2^{2018}$

56.  $\frac{a^2 + b^2}{a \cdot b} = 3 \Rightarrow \frac{a^2}{b^2} + \frac{b^2}{a^2} = ?$ 

- A) 10                      B) 11                      C) 7  
D) 9                      E) 8

57.  $9x^2 - 1 = 0$ 

$\Rightarrow$   $\left. \begin{array}{l} \text{Çözüm kümesi} \\ \text{Solution set} \\ \text{набор решений} \\ \text{مجموعة الحل} \end{array} \right\} ?$

- A)  $\left\{-\frac{1}{3}\right\}$                       B)  $\left\{-\frac{1}{3}, \frac{1}{3}\right\}$                       C)  $\left\{\frac{1}{3}\right\}$   
D) 1                      E) 0

58.  $\log_{\sqrt{5}-2}(\sqrt{5}+2) + \log_{\sqrt{7}+\sqrt{6}}(\sqrt{7}-\sqrt{6}) = ?$

- A) -2                      B) -1                      C) 0  
D) 1                        E) 2

59.  $\log_5(2x+85) = 3$

$\Rightarrow x = ?$

- A) 16                      B) 17                      C) 18  
D) 19                      E) 20

60.  $\lim_{x \rightarrow 2}(x^3 - 2ax^2 + 3) = 3$

$\Rightarrow a = ?$

- A) 0                        B) 1                        C) 2  
D) 3                        E) 4

61.  $\lim_{x \rightarrow 3} \frac{f(x) - 2}{x^2 - 9} = 5$

$\Rightarrow \lim_{x \rightarrow 3} \frac{f(x) + 2x - 8}{x - 3} = ?$

- A) 20                      B) 26                      C) 29  
D) 32                      E) 43

62.  $f(x) = \sqrt{x+14}$

$g(x) = 2^{x+3}$

$\Rightarrow (f+g)(2) = ?$

A) 20

B) 27

C) 36

D) 40

E) 63

64.  $f: \mathbb{R} \rightarrow \mathbb{R}$

$f(x) = e^{2x+1}$

$\Rightarrow (f^{-1})'(7) = ?$

A)  $\frac{1}{14}$

B)  $\frac{1}{7}$

C)  $\frac{1}{2}$

D)  $e^7$

E)  $\frac{1}{e^7}$

63.

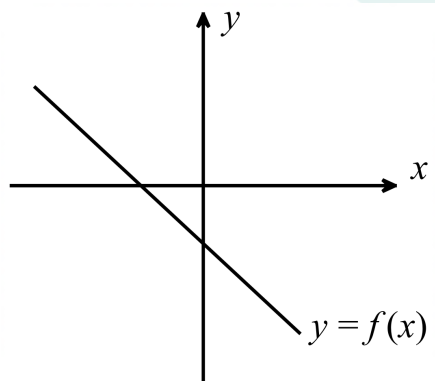

$f^2(x) = x^2 + 6x - 2f(x) + 8$

$\Rightarrow f(3) = ?$

A) 5

B) 2

C) 0

D) -2

E) -7

65.  $f(x) = x \cdot (x - 1) \cdot (x - 2) \dots (x - 6)$

$\Rightarrow \frac{f'(1)}{f'(6)} = ?$

- A)  $\frac{1}{2}$       B)  $-\frac{1}{2}$       C) 0  
 D)  $-\frac{1}{6}$       E)  $\frac{1}{6}$

66.  $A = \prod_{n=1}^3 \left( \sum_{m=1}^2 m^n \right)$

$B = \sum_{m=1}^3 \left( \prod_{n=1}^2 m^n \right)$

$\Rightarrow A + B = ?$

- A) 140      B) 150      C) 171  
 D) 182      E) 193

67.  $\int_{\frac{1}{e}}^e \ln x \cdot dx = ?$

- A)  $\frac{2}{e}$       B)  $\frac{1}{e}$       C) 1  
 D)  $e$       E)  $2e$

68.

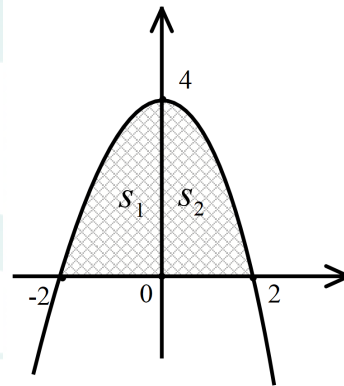

$y = f(x) = ax^2 + bx + c$

$S_1 + S_2 = ?$

- A)  $\frac{16}{3}$       B)  $\frac{8}{3}$       C)  $\frac{32}{3}$   
 D)  $\frac{64}{3}$       E)  $\frac{20}{3}$

69.  $\bar{z} + i\bar{z} = z + 4$

$$\Rightarrow z = ?$$

- A)  $8 - 4i$       B)  $4 - 8i$       C)  $4 + 8i$   
D)  $1 + i$       E)  $8 + 4i$

70.  $\frac{\sin 2x + 1}{\sin x + \cos x} - \sin x = ?$

- A)  $\sin x$       B) 1      C)  $\sin 2x$   
D)  $\cos x$       E)  $\cos 2x$

71.  $\frac{\cos 80^\circ + \cos 10^\circ}{\sin 80^\circ + \sin 10^\circ} = ?$

- A) 1      B)  $\frac{1}{2}$       C)  $\frac{1}{\sqrt{3}}$   
D)  $\sqrt{3}$       E) 2

72.  $\begin{bmatrix} 8 & 3 \\ 5 & 2 \end{bmatrix} \cdot A = \begin{bmatrix} 1 & 2 \\ -1 & 3 \end{bmatrix}$

$$\Rightarrow A = ?$$

- A)  $\begin{bmatrix} 5 & -5 \\ -13 & -14 \end{bmatrix}$       B)  $\begin{bmatrix} 13 & 14 \\ 5 & -5 \end{bmatrix}$       C)  $\begin{bmatrix} 5 & -5 \\ 13 & 14 \end{bmatrix}$   
D)  $\begin{bmatrix} 5 & -5 \\ -13 & 14 \end{bmatrix}$       E)  $\begin{bmatrix} 5 & 13 \\ -5 & 14 \end{bmatrix}$

73.  $n, A \in \mathbb{N}^+ = ?$

$$76! = 8^n \cdot A$$

$$\Rightarrow \max(n) = ?$$

A) 21

B) 24

C) 23

D) 22

E) 25

75.  $1 < y < 3,$

$$2x - y = 5$$

$$\Rightarrow ? < x < ?$$

A)  $1 < x < 2$

B)  $2 < x < 3$

C)  $5 < x < 6$

D)  $4 < x < 5$

E)  $3 < x < 4$

74.  $(x + 2) \cdot P(x - 1) = 3x^2 - 8x + k$

$$\Rightarrow P(-3) = ?$$

A) -16

B) -19

C) -20

D) -22

E) -23

76.

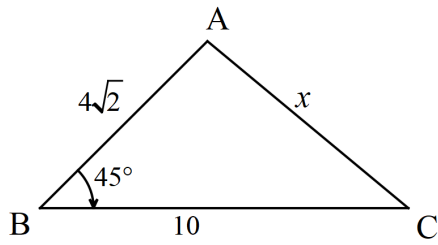

$$m(\widehat{ABC}) = 45^\circ$$

$$|AB| = 4\sqrt{2}br$$

$$|BC| = 10br$$

$$|AC| = x br$$

$$\Rightarrow x = ?$$

A)  $2\sqrt{13}$

B) 6

C) 7

D)  $3\sqrt{3}$

E) 8

77.

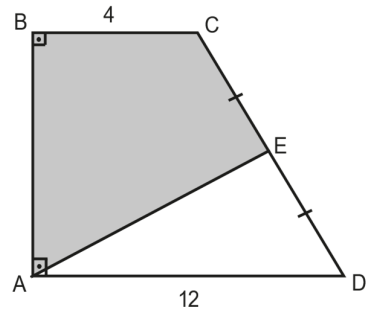

$$[AD] // [BC]$$

$$|CE| = |ED| = 5br$$

$$|BC| = 4br$$

$$|AD| = 12br$$

$$\Rightarrow A(ABCE) = ? br^2$$

A) 12

B) 18

C) 24

D) 30

E) 36

78.

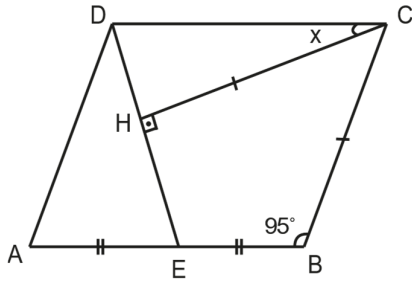

$[AD] // [BC], [DC] // [AB]$

$[CH] \perp [DE]$

$|AE| = |EB|, |CH| = |BC|$

$m(\widehat{ABC}) = 95^\circ$

$\Rightarrow m(\widehat{HCD}) = ?$

A) 15

B) 20

C) 25

D) 30

E) 35

79.

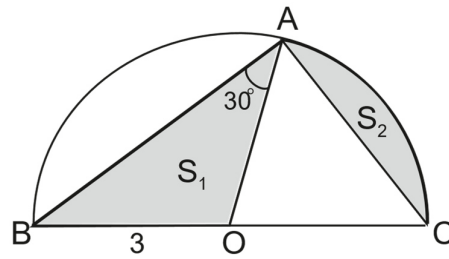

O Merkez/Centre/центр/ مرکز

$m(\widehat{BAO}) = 30^\circ$

$|OB| = 3br$

$\Rightarrow S_1 + S_2 = ?$

A)  $\pi$

B)  $\frac{3\pi}{2}$

C)  $2\pi$

D)  $\frac{5\pi}{2}$

E)  $3\pi$



80.

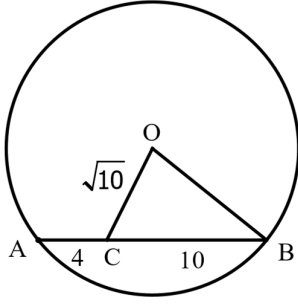

O Merkez/Centre/ центр/ مرکز

$$|OC| = \sqrt{10} br$$

$$|AC| = 4br$$

$$|CB| = 10br$$

$$\Rightarrow |OB| = ? br$$

A) 5

B) 6

C)  $3\sqrt{5}$ D)  $4\sqrt{3}$ E)  $5\sqrt{2}$ 

*Test Bitti / End of Test*